

# JVC

## SERVICE MANUAL

### CAMESCOPE COMPACT VHS

# GR-SX17EG, SXM27EG, SXM307EG

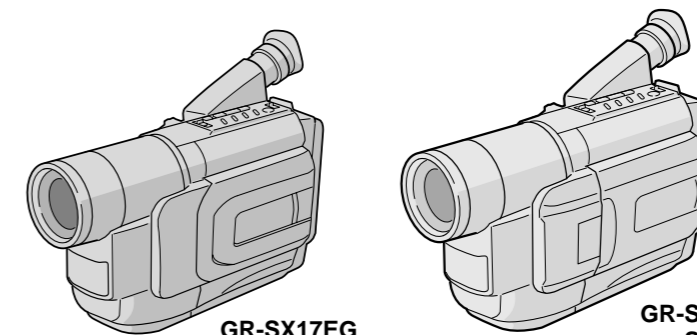

**VHS** PAL  
625

**Super VHS**  
**Super VHS ET**

Regarding service information other than these sections, refer to the GR-SXM607EG service manual (No. 86589). Also, be sure to note important safety precautions provided in the service manual.

### CARACTERISTIQUES TECHNIQUES

Camescope		Connecteurs	
<b>Général</b>		<b>JLIP/EDIT</b> : ø3,5 mm, 4 pôles, prise mini tête (compatible avec la fiche RC-5325)	
<b>Format</b> : Standard S-VHS/VHS PAL	<b>Humidité de fonctionnement</b> : 35% à 80%	<b>Vidéo</b> : 1 Vcc, 75 Ω asymétrique, sortie analogique (via la prise de sortie vidéo)	<b>Audio</b> : 300 mV (rms), 1 kΩ, sortie analogique (via la prise de sortie audio)
<b>Alimentation</b> : 11 V CC (En utilisant l'adaptateur secteur) 6 V CC (En utilisant la batterie)	<b>Température de stockage</b> : -20°C à 50°C	<b>S-Vidéo</b> : Y : 1 Vcc, 75 Ω, sortie analogique C : 0,29 Vcc, 75 Ω, sortie analogique	
<b>Consommation</b>	<b>Poids</b> : Environ 900 g (GR-SXM307 uniquement) Environ 910 g (GR-SXM27 uniquement) Environ 730 g (GR-SX17 uniquement)	<b>Adaptateur secteur AP-V10EG</b>	
<b>Viseur allumé</b> : 4,0 W (GR-SXM307/SXM27 uniquement) 3,7 W (GR-SX17 uniquement)	<b>Dimensions (L x H x P)</b> : 200 mm x 112 mm x 118 mm (GR-SXM307/SXM27 uniquement) 200 mm x 112 mm x 115 mm (GR-SX17 uniquement) (avec l'écran LCD* fermé et le viseur complètement incliné vers le bas)	<b>Alimentation</b> : CA 110 V à 240 V~, 50 Hz/60 Hz	<b>Sortie</b> : CC 11 V, 1 A
<b>Écran LCD* allumé</b> : 4,5 W (GR-SXM307/SXM27 uniquement)	<b>Capteur</b> : CCD de 1/4"	<b>Dimensions (L x H x P)</b> : 59 mm x 31 mm x 84 mm	<b>Poids</b> : Environ 140 g (cordon secteur non compris)
<b>Torche vidéo**</b> : 3,0 W	<b>Objectif</b> : F1,6, f = 3,9 mm à 62,4 mm, zoom électrique 16:1 avec commande de diaphragme automatique et commande macro, diamètre du filtre 40,5 mm	<b>Accessoires en option</b>	
* Modèles disposant d'un écran LCD uniquement. ** GR-SXM307 uniquement.	<b>Viseur</b> : Viseur électronique avec tube à rayons cathodiques noir et blanc de 0,5"	<ul style="list-style-type: none"> <li>Batterie BN-V12U, BN-V20U, BN-V400U</li> <li>Cassettes compactes S-VHS (VHS) SE-C45/30</li> <li>Cassettes compactes VHS (VHS) EC-60/45/30</li> <li>Sac de transport CB-V7U</li> <li>Adaptateur de cassette C-P7U</li> </ul>	
<b>Système de signal</b> : Type PAL	<b>Réglage de la balance des blancs</b> : Automatique/manual	Certains accessoires ne sont pas disponibles dans certaines régions. Veuillez consulter votre revendeur JVC le plus proche avant d'acheter des accessoires en option.	
<b>Système d'enregistrement vidéo</b>	<b>Écran LCD (modèles disposant d'un écran LCD uniquement)</b> : 2,5" mesuré en diagonale, écran LCD/matrice active TFT (GR-SXM307/SXM27 uniquement)		
<b>Luminance</b> : Enregistrement FM	<b>Haut-parleur (modèles disposant d'un écran LCD uniquement)</b> : Monophonique		
<b>Couleur</b> : Enregistrement direct de sous-porteuse convertie Conforme au standard VHS			
<b>Cassette</b> : Cassette <b>VHS</b> / <b>VHS</b>			
<b>Vitesse de bande</b>			
<b>SP</b> : 23,39 mm/s			
<b>LP</b> : 11,70 mm/s			
<b>Durée maximale d'enregistrement</b>			
<b>SP</b> : 60 mn			
<b>LP</b> : 120 mn (avec une cassette EC-60)			
<b>Température de fonctionnement</b> : 0°C à 40°C			

# JVC

VICTOR COMPANY OF JAPAN, LIMITED  
VIDEO DIVISION

S40894

Printed in Japan

This service manual is printed on 100% recycled paper.  
COPYRIGHT © 2001 VICTOR COMPANY OF JAPAN, LTD.

No. 86610  
February 2001

## TABLE OF CONTENTS

<b>DIFFERENT TABLE</b> .....	1 to 3
<b>4. CHARTS AND DIAGRAMS</b>	
4.1 BOARD INTERCONNECTIONS .....	4-1
4.2 REGULATOR SCHEMATIC DIAGRAM .....	4-3
4.3 LCD CTL SCHEMATIC DIAGRAM .....	4-5
4.4 MAIN CIRCUIT BOARD .....	4-7
<b>5. PARTS LIST</b>	
5.1 PACKING AND ACCESSORY ASSMBLY <M1> .....	5-1
5.2 FINAL ASSEMBLY <M2> .....	5-3
5.3 ELECTRICAL PARTS LIST	
MAIN BOARD ASSEMBLY <01> .....	5-6

The following table indicate main different points between models GR-SXM607EG, SXM307EGF, SXM27EG-F and GR-SX17EG-F.

ITEM \ MODEL	GR-SXM607EG	GR-SXM307EGF	GR-SXM27EG-F	GR-SX17EG-F
LCD MONITOR	Used (3")	Used (2.5")	Used (2.5")	Not used
IMAGE SENSOR	470K	470K	320K	320K
BATTERY PACK	BN-V20BU	BN-V11U-F	BN-V11U-F	BN-V11U-F
BODY COLOR	Silver	Silver	Silver	Black
DC LIGHT	Used	Used	Not used	Not used
NIGHT SCOPE	Used	Used	Not used	Not used
S CABLE, S-VIDEO CABLE	Provided	Provided	Optional	Optional

The following table indicate different parts number between models GR-SXM607EG, SXM307EGF, SXM27EG-F and GR-SX17EG-F.

### PACKING AND ACCESSORY ASSEMBLY <M1>

REF. NO.	ITEM \ MODEL	GR-SXM607EG	GR-SXM307EGF	GR-SXM27EG-F	GR-SX17EG-F
1	PACKING CASE	LY32179-004A	←	←	LY32179-003A
△ 5	IB(FR)	LYT0671-003A	LYT0740-001A	←	←
7	WARRANTY/GUARANTY CARD	BT-54013-1	BT-54008-2	←	←
△ 10	AC ADAPTER	* LY20688-001A	LY20688-001B	←	←
△ 11	BATTERY PACK	LY31199-001A	YQ10629F	←	←
15	S CABLE,S-VIDEO CABLE	QAM0004-003	←	-	-
16	REMOTE CONTROL UNIT	LY42129-001A	-	-	-
17	AAA(R03)BATTERY,X2	Used	Not used	Not used	Not used
18	ADAPTER PLUG	QAM0302-001	←	-	-
19	CONNECTOR,CABLE ADAPTER	-	-	PEMC1174	←

Note: Mark - is not used. Mark ← is same as left. Mark \* reference model was also changed.

**FINAL ASSEMBLY <M2>**

REF. NO.	MODEL		GR-SXM607EG	GR-SXM307EGF	GR-SXM27EG-F	GR-SX17EG-F
	ITEM					
101	LOWER CASE ASSY		LY20684-008A	←	LY20684-007A	LY20684-003B
101D	SPEAKER		QAS0061-001	←	←	-
101E	HOLDER(SPEAKER)		LY42764-001B	←	←	-
101F	SCREW	*	QYSLSF2060D	QYSLSF2050Z	←	-
102	COVER(JACK)	*	LY31945-001B	LY31945-001C	←	←
104	FRONT COVER ASSY		LY20683-014A	←	LY20683-013A	LY20683-002B
104E	DC LIGHT/COVER(LIGHT)		LY32040-001A	←	LY30934-020A	LY30934-015A
104F	SPACER(A)		LY30029-0B4A	←	-	-
104H	CAUTION LABEL		YQ44341-6	←	-	-
104J	STICKER(A)		LY32058-002A	←	LY32058-001A	←
104K	STICKER(C)		LY32060-002A	←	LY32060-001A	←
105	CASS.COVER(M)ASSY		LY20694-002A	←	←	-
105B	SHIELD SHEET		LY40559-001A	←	←	-
105C	SPACER,X2		LY40076-001A	←	←	-
106	UPPER CASE(M)		LY10257-001A	LY10257-035A	LY10257-034A	-
109	TOP OPE UNIT		LY20614-002B	←	LY20614-014B	LY20614-004B
111	REAR UNIT		LY20615-001A	LY20615-004A	←	LY20615-003A
114	STICKER(D)		LY32061-001A	←	LY32061-003A	←
115	SCREW	*	QYSLSF2060D,X5	QYSLSF2060D,X4	←	←
118	SCREW,X2		QYSLSF2060D	←	←	-
121	SCREW,X3	*	QYSLSF2060D	QYSLSF2050Z	←	←
127,128	SCREW,X2		QYSLSP2030D	←	←	-
130	FRAME ASSY		LY20678-001A	←	LY20678-002A	←
130E	CONTACT(LIGHT),X2		YQ43810-1-1	←	-	-
130F	E-SI C WIRE C-F		WJM0167-001A	←	-	-
136	SCREW/SPECIAL SCREW	*	QYSLSF2060D	LY42981-001A	←	←
152	CASS.COV.INSIDE		LY30176-001A	←	←	LY31294-001B
153	BRACKET(C.COV.)		LY31956-001A	←	←	-
	BRACKET(C.C/S)		-	-	-	LY32026-001B
160	C.COVER(S)ASSY		-	-	-	LY20680-010A
160B	HINGE(C.COVER)		-	-	-	LY32024-001A
160C	SCREW,X2		-	-	-	QYSLSF2060D
160D	WINDOW(S)		-	-	-	LY32023-001A
161	BUTTON(P)ASSY		-	-	-	LY32041-001B
161A	COMPRES.SPRING		-	-	-	LY30002-049B
162	SCREW		-	-	-	QYSLSP2030D
163	U.COVER(S)ASSY		-	-	-	LY32038-001A
164,166	SCREW,X2		-	-	-	QYSLSF2060D
165	UPPER CASE(S)		-	-	-	LY10272-014A

Note: Mark - is not used. Mark ← is same as left. Mark \* reference model was also changed.

**OPTICAL BLOCK SECTION**

REF. NO.	MODEL		GR-SXM607EG	GR-SXM307EGF	GR-SXM27EG-F	GR-SX17EG-F
	ITEM					
254	OP LPF		LY41370-001A	←	LY41757-001A	←
255	CCD SPACER		LY20086-001A	←	LY20346-001A	←
257	CCD BASE ASSY		LYH40018-004A	←	LYH40018-003A	←

**MONITOR ASSEMBLY <M5>**

REF. NO.	MODEL		GR-SXM607EG	GR-SXM307EGF	GR-SXM27EG-F
	ITEM				
△ 500	MONITOR ASSY		LYH20217-001A	LYH20217-023A	LYH20217-010A
△ 501	M.COVER ASSY		LY20679-001A	←	LY20679-002A
501B	WINDOW		LY32022-004A	←	LY32022-002A
502	M.CASE(3/2.5)ASSY		LY32035-001A	LY32036-001A	←
515	HOLDER(3/2.5PWB)		LY20647-001A	LY20672-001B	←
519	BACK LIGHT		QLL0094-001	QLL0093-001	←
520	LCD MODULE		QLD0118-001	QLD0176-001	←

**MAIN BOARD ASSEMBLY <01>**

REF. NO.	MODEL		GR-SXM607EG	GR-SXM307EGF	GR-SXM27EG-F	GR-SX17EG-F
	ITEM					
PW	MAIN BOARD ASSY		YB10310EB-01	YB10310FB-02	YB10310FA-02	YB10310EW-02

**MONITOR BOARD ASSEMBLY <07>**

REF. NO.	MODEL		GR-SXM607EG	GR-SXM307EGF	GR-SXM27EG-F
	ITEM				
PW	MONITOR BOARD ASSY		YB20900A-01	YB20900B-01	←
R7511,R7512	MG RESISTOR		NRSA63J-223X	-	-
R7513	MG RESISTOR		-	NRSA63J-103X	←
R7514	MG RESISTOR		NRSA63J-333X	-	-
R7515	MG RESISTOR		NRSA63J-562X	NRSA63J-302X	←
C7510	CAPACITOR		NCB31EK-103X	-	-

Note: Mark - is not used. Mark ← is same as left.